

NAME	MATERIAL	QTY
Part 1	1-1/2" x 1/2" WT x 45.5"	2
Part 2	3/8" x 3/4" x 42-3/4"	11
Part 3	3/8" x 3/8" x 42-1/4"	2
Part 4	1-1/2" x 1-1/2" x 1/4" X29"	2
Part 5	5/16" x 1/2" X 29"	2
Part 6	3/8" x 3/8" X 29"	2
Part 7	Dia 3/8" X 29"	23
Part 8	41.58" x 29.00" x 0.20" WT	1

SECTION A-A
SCALE 1 : 12

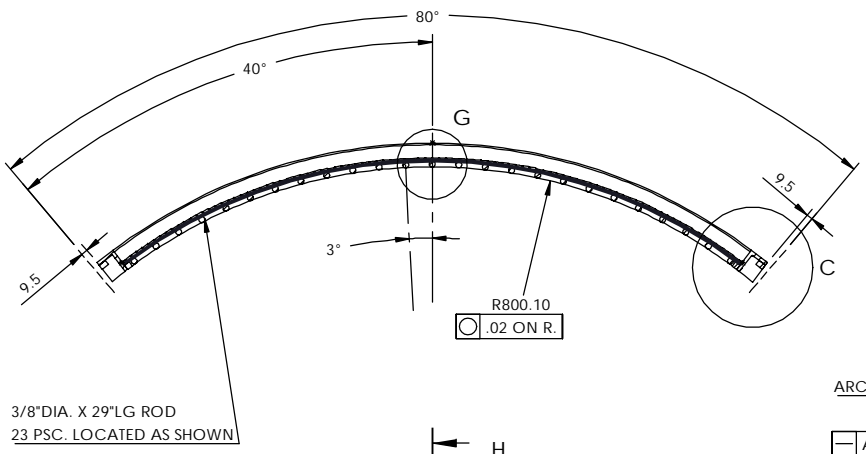

3/8" DIA. X 29" LG ROD
23 PSC. LOCATED AS SHOWN

R800.10
.02 ON R.

.02 ON R.
33.00" R
ARC LENGTH 45.33 ± .06

-	A	.01
//	A	.06

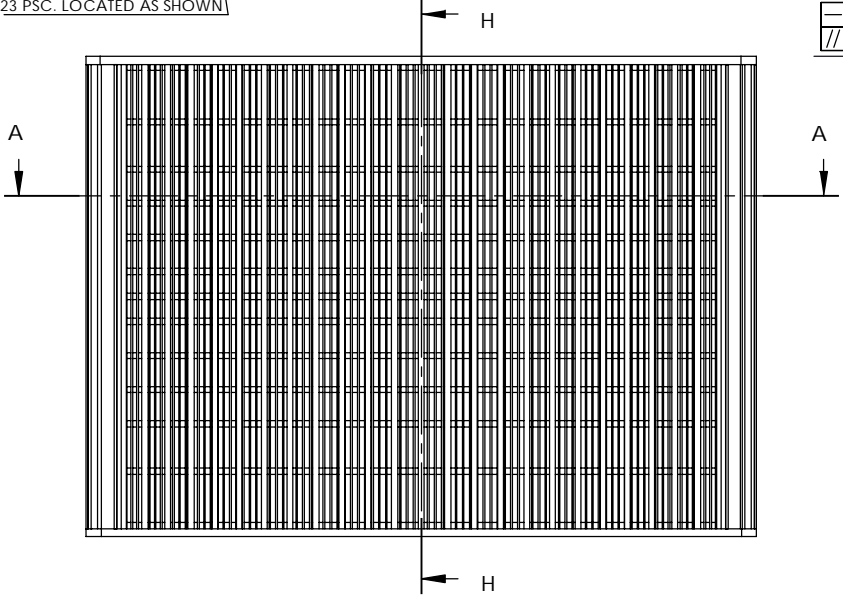

NOTE : STRAINER ELEMENT EXPETED LIPE : 2 YEAR
SCREEN SIZE : 41.58" X 29.00"
MATERAIAL : STAINLESS STEEL TYPE 316

SECTION H-H
SCALE 1 : 12

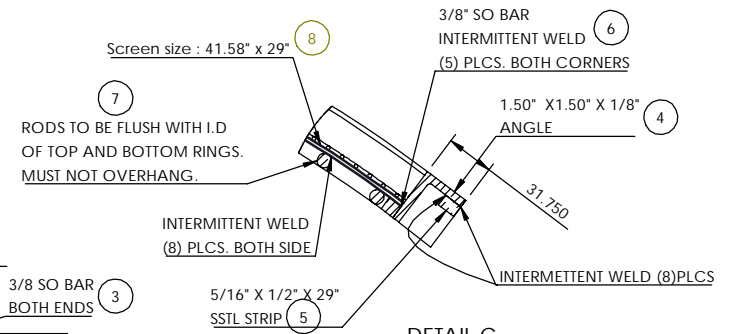
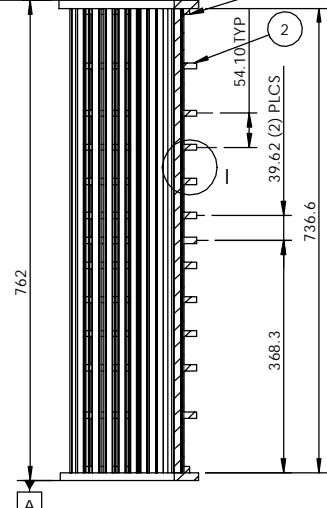

DETAIL C
SCALE 1 : 5

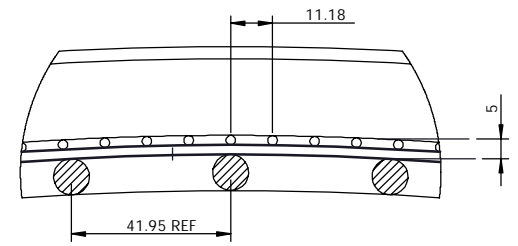

DETAIL G
SCALE 1 : 2

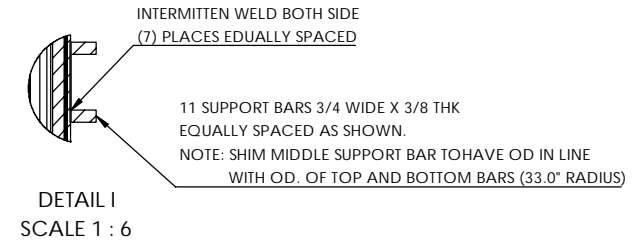

DETAIL I
SCALE 1 : 6